

## SPECIFICATIONS

### DESCRIPTION

- Stainless steel filter housing
- Katadyne filter
- Flow regulated filtration for optimum performance
- Filters down to 0.2 microns
- Activated carbon core reduces chlorine, odour and bad taste
- Heavy metal removal

### FLOW

- Recommended working pressure 0.5 bar/7.5PSI
- Maximum 5 bar/ 75 PSI
- 6L /min at 1 bar
- 12L /min at 3 bar

### WARRANTY

- [www.perrinandrowe.co.uk](http://www.perrinandrowe.co.uk)

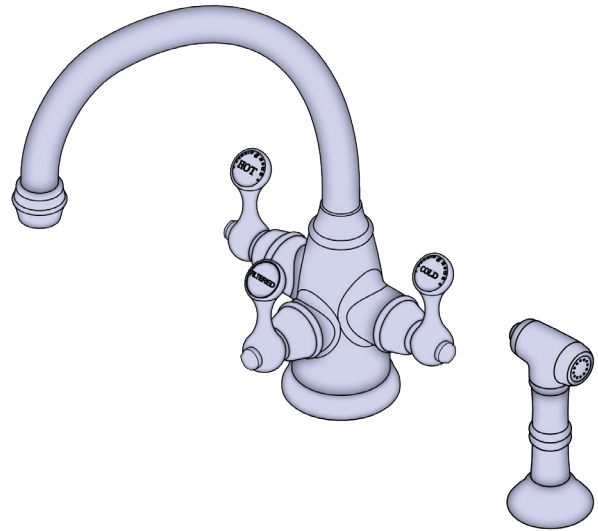

## Sink Mixer with Filtration and Rinse

MODELS: E.1520

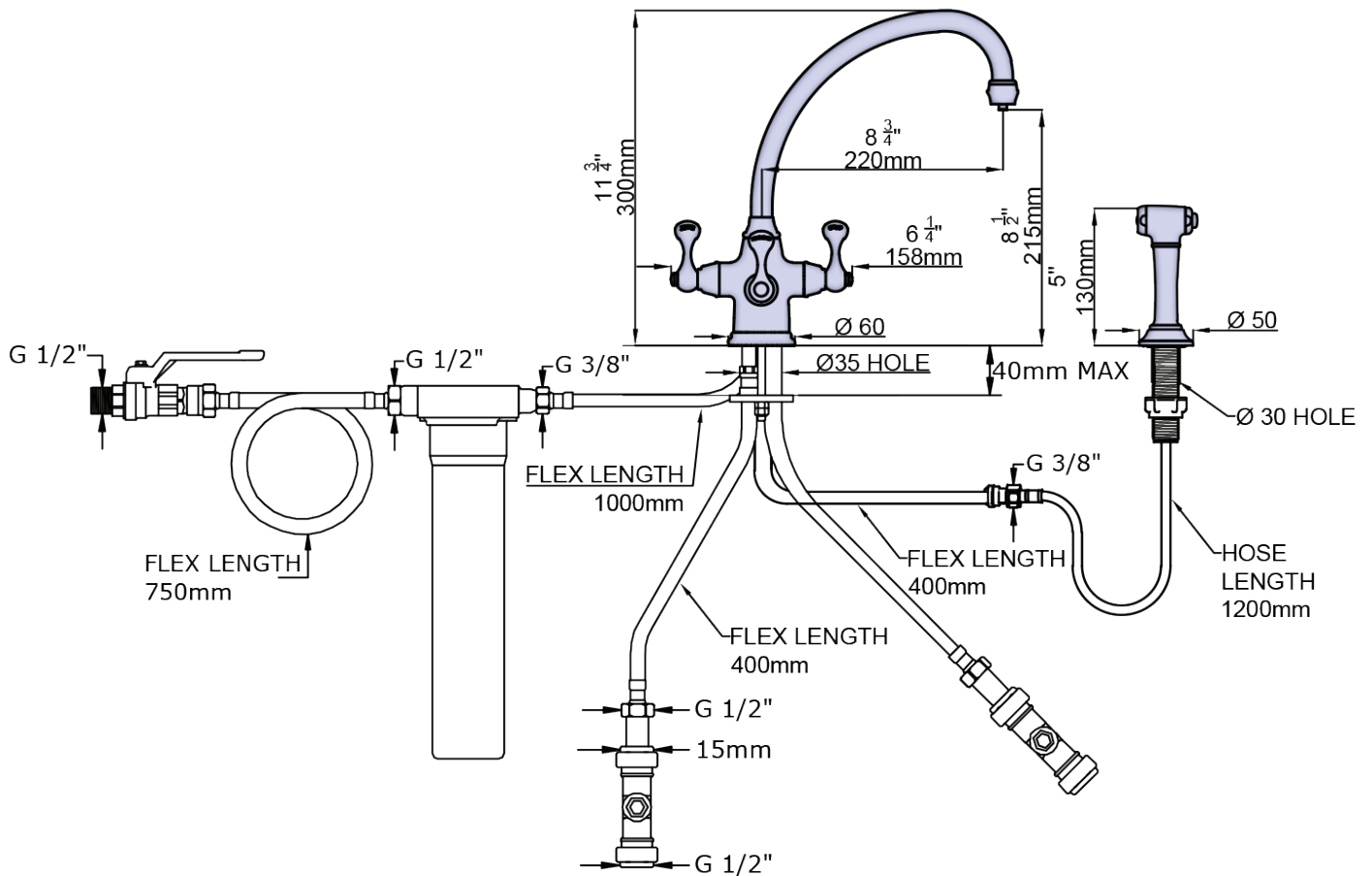

+44 (0) 1708 526 361

[www.perrinandrowe.co.uk](http://www.perrinandrowe.co.uk)

A DISTINCTIVE MEMBER OF THE HOUSE OF ROHL



## CARACTERÍSTICAS TÉCNICAS

### DESCRIPCIÓN

- Carcasa del filtro de acero inoxidable
- Filtro Katadyne
- Filtro con caudal regulado para un rendimiento óptimo
- Filtra hasta 0,2 micras
- El núcleo de carbón activo reduce el cloro, el olor y el mal sabor
- Eliminación de metales pesados

### CAUDAL

- Presión de instalación recomendada 0.5 bar/7.5PSI
- Máximo 5 bar/ 75 PSI
- 10L /min at 1 bar
- 17L /min at 3 bar

### GARANTÍA

- [www.perrinandrowe.co.uk](http://www.perrinandrowe.co.uk)

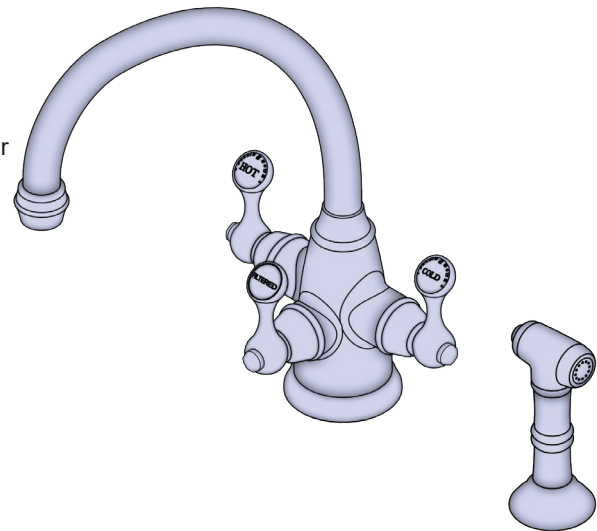

## Mezclador bimando de cocina con agua filtrada y ducha lateral extraíble

MODELOS: E.1520

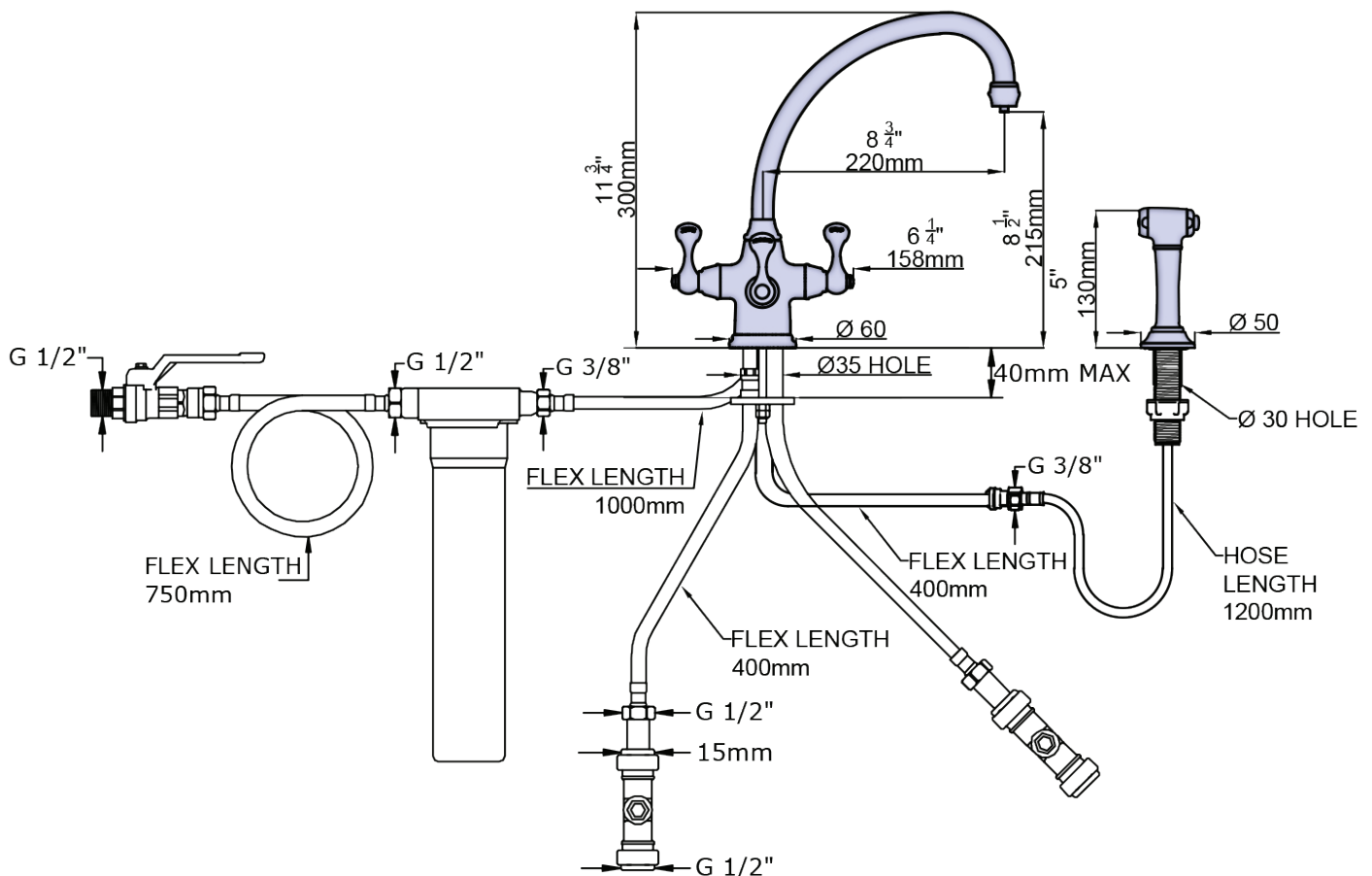

+44 (0) 1708 526 361

[www.perrinandrowe.co.uk](http://www.perrinandrowe.co.uk)

A DISTINCTIVE MEMBER OF THE HOUSE OF ROHL

## CARACTÉRISTIQUES TECHNIQUES

### DESCRIPTION

- Boîtier de filtre en acier inoxydable
- Filtre Katadyne
- Filtration à débit régulé pour une performance optimale
- Filtres jusqu'à 0,2 microns
- Le noyau de carbone activé réduit le chlore, l'odeur et le mauvais goût
- Élimination des métaux lourds

### DÉBIT

- Pression d'installation recommandée 0.5 bar/7.5PSI
- Maximum 5 bar/ 75 PSI
- 10L /min at 1 bar
- 17L /min at 3 bar

### GARANTIE

- [www.perrinandrowe.co.uk](http://www.perrinandrowe.co.uk)

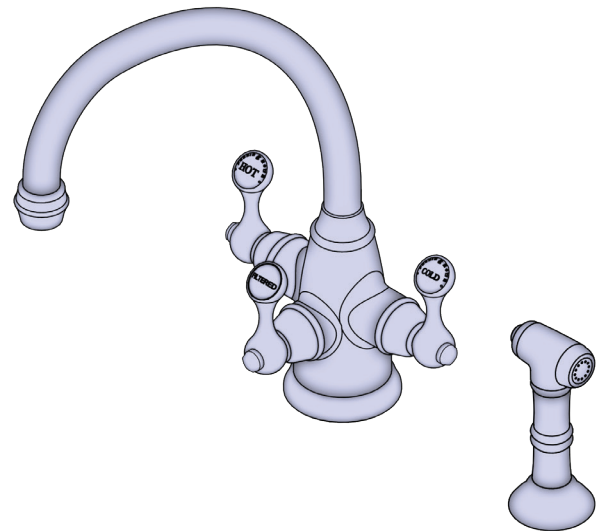

## Mélangeur évier avec eau filtrée et douchette latérale extractible

MODÈLES: E.1520

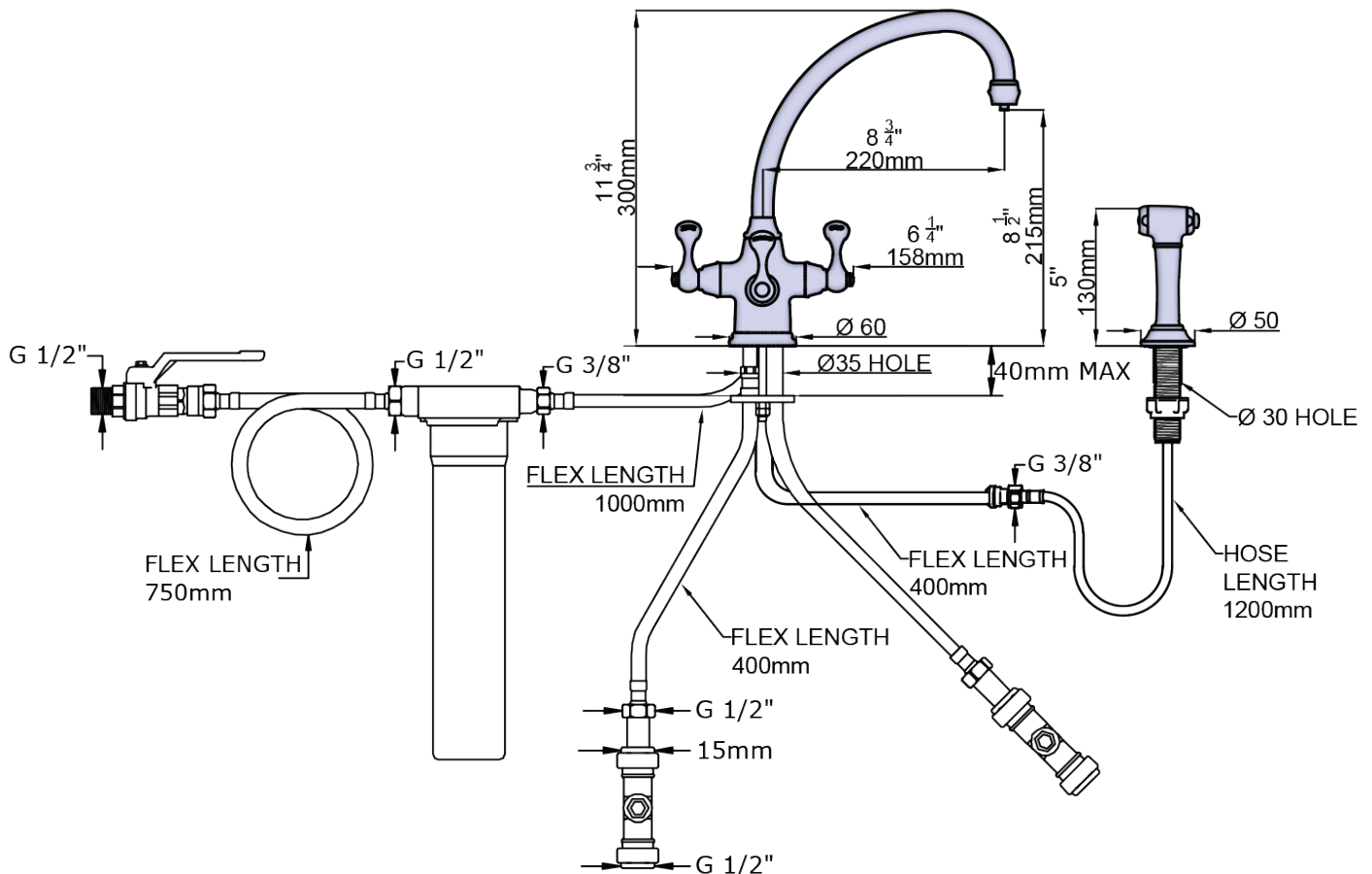

+44 (0) 1708 526 361

[www.perrinandrowe.co.uk](http://www.perrinandrowe.co.uk)

A DISTINCTIVE MEMBER OF THE HOUSE OF ROHL



## SPECIFICATIES

### Beschrijving

- Roestvrijstalen filterhuis
- Katadyne filter
- Stroomgeregelde filtratie voor optimale prestaties
- Filtert tot 0,2 micron
- Geactiveerde koolstofkern vermindert chloor, geur en slechte smaak
- Verwijdering zware metalen

### Stromingsdruk

- Aanbevolen installatiedruk 0.5 bar/7.5PSI
- Maximaal 5 bar/ 75 PSI
- 10L /min at 1 bar
- 17L /min at 3 bar

### Garantie

- [www.perrinandrowe.co.uk](http://www.perrinandrowe.co.uk)

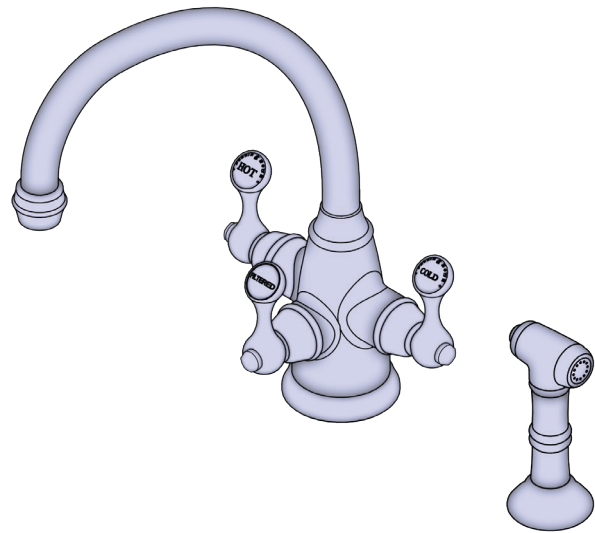

## Keukenmengkraan met filterfunctie en spoeler

MODELLEN: E.1520

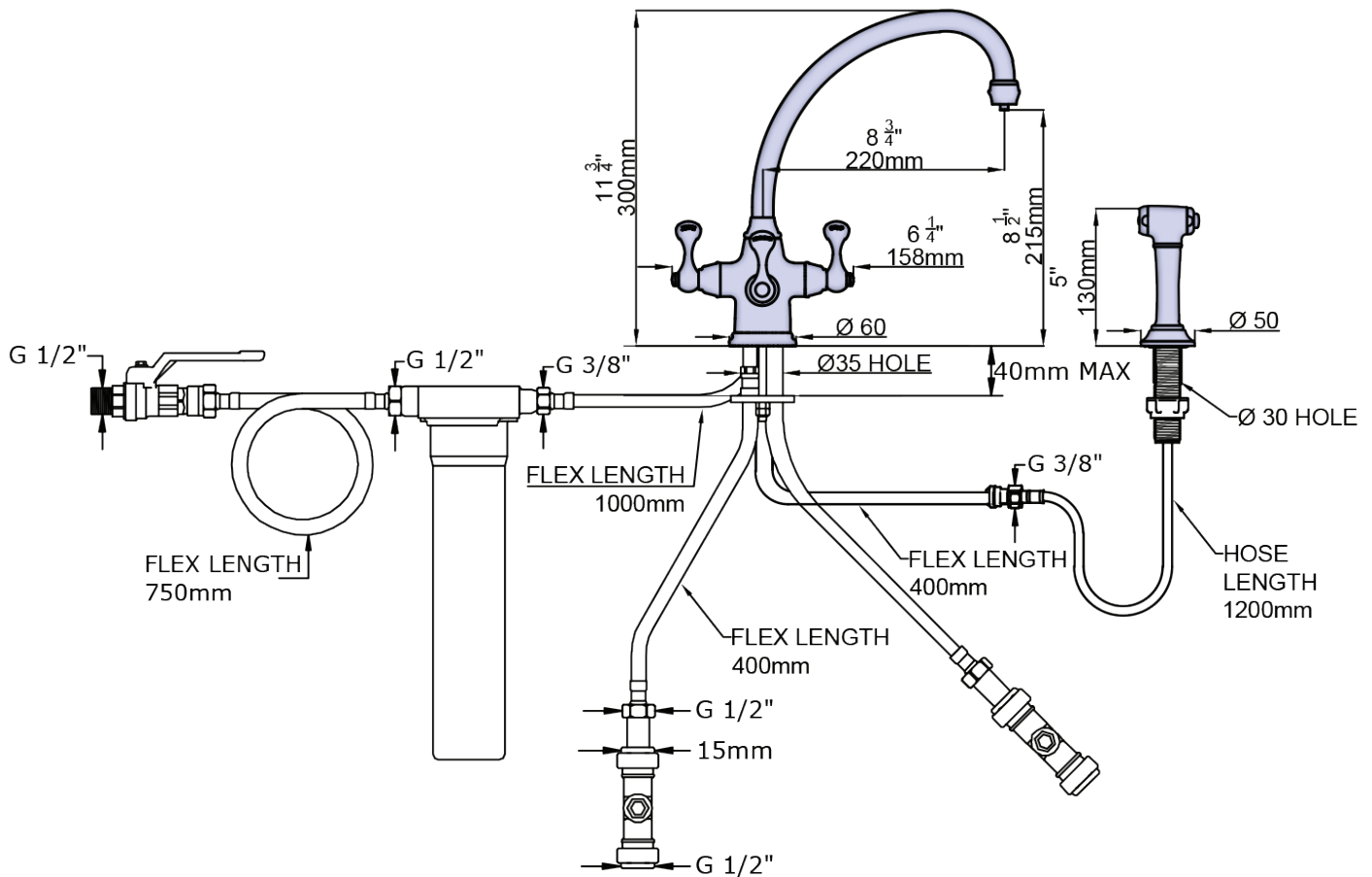

+44 (0) 1708 526 361

[www.perrinandrowe.co.uk](http://www.perrinandrowe.co.uk)

A DISTINCTIVE MEMBER OF THE HOUSE OF ROHL