

Longdon 2 KETTLE v7

HOT WATER APPLIANCE

clearwater
THE CLEAR CHOICE



Please Keep Me Safe

Installation, Operation & Care Instructions

Please read these instructions fully before commencing the installation and operation of the Electronic Instant Hot Water Appliance

All designs, descriptions and dimensions are subject to change without notice.

GUARANTEE AND LIABILITY

In the unlikely event that you should experience any defect in the material or workmanship of your mixer tap or tank within 5 years (tap) and 2 years (kettle tank) from date of purchase, we will replace the faulty part free of charge.

The Clearwater Kettle water filter must be replaced every 6 months regardless of the filter icon position. Failure to do so will invalidate your product warranty. Only use genuine Clearwater kettle filters.

Decorative surface finishes are guaranteed for one year from the date of purchase provided that our advise concerning care has been observed and no scouring agents have been used. This is provided that the mixer or tap has been used for normal domestic purposes in the UK and that the care, installation and maintenance instructions have been observed.

Scuff and scratches caused by normal wear and tear, improper installation or accidental damage are excluded from this guarantee.

You should retain a copy of your dated invoice as proof of purchase to validate any claims under this guarantee.

No other warranties, express or implied, are made, including merchantability or fitness for a particular purpose.

Need Help Scan me

Register your warranty:

Fill in your free post form or register your tap/tank by scanning the QR



AFTER CARE

To maintain the appearance of this tap, ensure that it is regularly cleaned using only a clean, soft damp cloth. A solution of warm water and a mild liquid detergent may be used where necessary, and then the fitting rinsed thoroughly and wiped dry. Abrasive cleaners, scouring cleaners and acid cleaners **must not be** used under any circumstances. All bath cleaning powders and liquids will damage the surface of your fitting even the non-scratch cleaners.

Avoid contact with all solvents and any harsh household chemicals. You will damage the plated finish and void your guarantee.

Spare Parts & Service

sterling
SINKS & TAPS

Phone: 01684 299555

Email: orders@sterling.eu.com

Website: www.sterling.eu.com

INSTALLATION

1. Install the tap assembly

- Thread the tails through the base ring (T9T3A9C) and a pre-drilled 35 mm tap hole.
- Position the tap in its designed location.
- From below the sink, install the washers in this order: Rubber washer, then Metal washer
- Install the fixing nut and tighten. (Use Tool Z00031N to assist with securing the tap)

2. Install the cold-mains isolation components

- Install the C7 Isolation Tee onto the cold mains supply.
- If the property's supply pressure exceeds 3 bar, install the C26 Pressure Reducing Valve (PRV) before the C7 Isolation Tee.
- Install the C26 adapter onto the C7.

3. Mount the filter head

- Find a suitable location for the filter and head (C3/C2).
- Ensure at least 5 cm of space below the filter and base of cabinet - for replacement clearance
- Secure the filter head to the cabinet wall using the supplied C6 screws.

4. Connect the pipework to the filter

- Using the C6 piping, measure, cut, and install the connection between C26 and the left-hand side of the C3 filter head.
- Cut the pipe and connect C6 pipe to the right-hand side of the C3 filter head to the C30 Tee.

5. Connect the tap tail

- Push the tap tail connections into the C30 Tee.

6. Install the kettle tank

- Position the kettle tank at least 100 mm away from the filter to prevent heat transfer.
- Push the C15 silicone pipe onto the centre barbed connector of the tank and secure with the C19 spring clip.
- Push one C28 adapter onto the tap fixing shank.
- Push the second C28 adapter onto the tank inlet connector (identified by a blue nut).
- Use the remaining C6 pipe to complete the connection between the tap and the tank.

7. Flush and prime the system

- Open the isolation Tee.
- Run the filtered water function for 3 minutes to flush the filter.
- Operate the boiling function for 2 minutes to prime the tank and remove any remaining air pockets.

8. Power and initialisation

- Connect the tank to the mains power supply.
- Press and hold the Standby symbol on the tank to start the initial boiling procedure.

In the unlikely event you find a part missing please contact our Customer Service Helpline on 01684 299555 for immediate despatch of part.

COMPONENTS PLAN

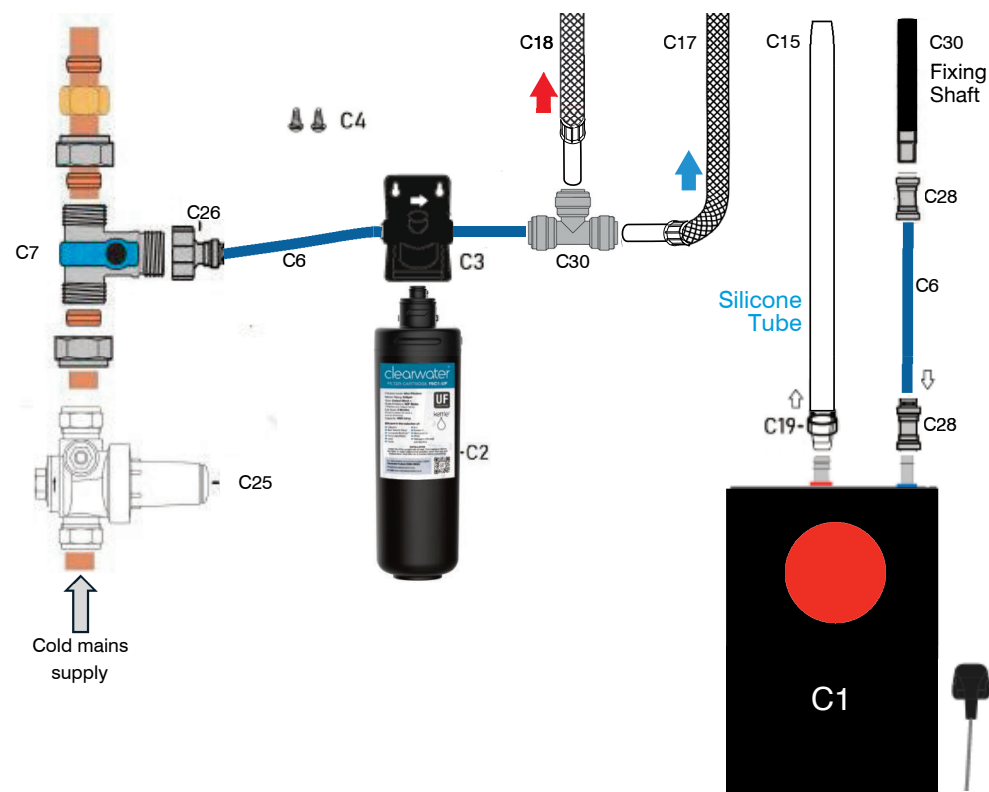

Ref	Description	Qty
C1	Kettle tank	1
C2	F6C1-UF filter	1
C3	3/8 Filter head	1
C4	Pozi screws	2
C6	3/8 tubing	1
C7	3-way Tee (with isolation)	1
C15	Silicone hose	1
C17	Filtered supply tail	1
C18	Filtered supply tail (boiling)	1
C19	Silicone hose spring clip	1
C28	3/8 Equal straight connector	2
C30	Fixing shank/ boiler supply	1
C31	3/8 Equal Tee	1

IMPORTANT SAFETY INSTRUCTIONS

PLEASE READ ALL INSTRUCTIONS CAREFULLY



When using all electrical appliances, basic safety precautions should always be followed including the information below:

To protect against electrical shock, do not place cord, plugs or unit near or in water or other liquids and do not operate the electronic instant hot water appliance controls or power socket with wet hands.

Check the power rating of your electronic instant hot water appliance is suitable for the power rating of the electrical circuit it is being installed on.

Do not operate or install the electronic instant hot water appliance if it appears to have any missing parts, be damaged/faulty eg damaged cord, plug.

Do not use outdoors or in a damp area.

Do not use the electronic instant hot water appliance for anything other than the intended Domestic use.

The electronic instant hot water appliance must be installed vertically as shown on front cover with inlet and outlet connections at the top of appliance.

Ensure the front of the unit is visible and the front temperature dial can be easily reached.

Do not attempt to open, modify or service this electronic instant hot water appliance. Repairs should be carried out by Authorised Service personnel. Opening the unit will void the guarantee.

In areas of high water pressure above 5 bar a pressure reducing valve must be fitted or the electronic instant hot water appliance guarantee will be void.

Turn off all controls before unplugging.

Do not unplug by pulling the cable. To unplug, grasp the plug, not the cable.

Property Damage:

To avoid the risk of flooding, regularly inspect the unit for any signs of leakage.

This electronic instant hot water appliance is not intended for use by persons (including children) with reduced physical, sensory or mental capabilities, or lack of experience and knowledge, unless they have been given supervision or instruction concerning use of the appliance by a person responsible for their safety.

Children should be supervised at all times.

INSTALLATION REQUIREMENTS

Electrical Requirements

IMPORTANT: Observe all local governing codes and ordinances.

A 220/240 volt, 50 Hz, AC-only 13 amp fused, grounded electrical power supply is required. It is recommended that a separate circuit serving only your electronic instant hot water appliance be provided or use an outlet that can be turned on/off by a switch. This electronic instant hot water appliance is equipped with a standard UK3 pin plug. To minimise possible shock hazard, the cord must be plugged into mating, ground-type outlet, grounded in accordance with all national and local codes and ordinances. If a socket outlet is not available, it is the responsibility and obligation of the customer to have a properly grounded outlet installed by a qualified electrician.

Water Supply Requirements

IMPORTANT: If the water pressure to the hot water dispenser system is less than 150kPa (1.5 bar), performance may be affected. Also if the pressure of water inlet is above 500kPa (5 bar), the electronic instant hot water appliance may be damaged and will void the guarantee so an approved pressure reducing valve must be installed by a plumber.

We strongly recommend installing particle filters and isolation valves to both hot and cold feeds. This will help to prevent premature failure of valves and make any future maintenance easier. Flush the plumbing system before installing the mixer tap. This is to void plumbing residues clogging the mesh of the aerated outlet, or possibly damaging the valve's washers. This is especially important where extensive plumbing work has been carried out.

Environment Requirement

Don't install the electronic instant hot water appliance outdoors or in a location that may fall below zero degrees C, otherwise the pipes and the tap may freeze and there may be serious safety risks, possible bodily-injury, accidents and damaged caused.

The installation environment should be ventilated, with protection from the direct sunshine. When installing the electronic instant hot water appliance, provide approximately 10cm to 15cm (4 - 5 1/2") of air space on the sides of the unit for air circulation and approximately 2.5cm (1") from the mounting wall. Ensure that the electronic instant hot water appliance is placed so that you will be able to view and reach the touch control on the front face for adjustments.

The electronic instant hot water appliance must be mounted vertically and level. Before you begin, select a proper location ideally directly under the instant hot water tap or close to it to ensure the connection pipes will connect from the instant hot water tap to the electronic instant hot water appliance.

Instant Hot Water Tap Information

Unlike other household hot water appliances, this electronic instant hot water appliance is Non Pressurised for safety reasons. For this electronic instant hot water appliance, the Instant Hot Tap is placed before the electronic instant hot water appliance, creating an "open vent" system and consequently no pressure is built up inside the appliance. Consequently, there is a slight delay in water flow after the Hot Water Handle has been turned on. This is normal and indicates that the electronic instant hot water appliance is functioning properly.

IMPORTANT SAFETY INSTRUCTIONS

PLEASE READ ALL INSTRUCTIONS CAREFULLY



When using all electrical appliances, basic safety precautions should always be followed including the information below:

To protect against electrical shock, do not place cord, plugs or unit near or in water or other liquids and do not operate the electronic instant hot water appliance controls or power socket with wet hands.

Check the power rating of your electronic instant hot water appliance is suitable for the power rating of the electrical circuit it is being installed on.

Do not operate or install the electronic instant hot water appliance if it appears to have any missing parts, be damaged/faulty eg damaged cord, plug.

Do not use outdoors or in a damp area.

Do not use the electronic instant hot water appliance for anything other than the intended Domestic use.

The electronic instant hot water appliance must be installed vertically as shown on front cover with inlet and outlet connections at the top of appliance.

Ensure the front of the unit is visible and the front temperature dial can be easily reached.

Do not attempt to open, modify or service this electronic instant hot water appliance. Repairs should be carried out by Authorised Service personnel. Opening the unit will void the guarantee.

In areas of high water pressure above 5 bar a pressure reducing valve must be fitted or the electronic instant hot water appliance guarantee will be void.

Turn off all controls before unplugging.

Do not unplug by pulling the cable. To unplug, grasp the plug, not the cable.

Property Damage:

To avoid the risk of flooding, regularly inspect the unit for any signs of leakage.

This electronic instant hot water appliance is not intended for use by persons (including children) with reduced physical, sensory or mental capabilities, or lack of experience and knowledge, unless they have been given supervision or instruction concerning use of the appliance by a person responsible for their safety.

Children should be supervised at all times.

INSTALLATION REQUIREMENTS

Electrical Requirements

IMPORTANT: Observe all local governing codes and ordinances.

A 220/240 volt, 50 Hz, AC-only 13 amp fused, grounded electrical power supply is required. It is recommended that a separate circuit serving only your electronic instant hot water appliance be provided or use an outlet that can be turned on/off by a switch. This electronic instant hot water appliance is equipped with a standard UK3 pin plug. To minimise possible shock hazard, the cord must be plugged into mating, ground-type outlet, grounded in accordance with all national and local codes and ordinances. If a socket outlet is not available, it is the responsibility and obligation of the customer to have a properly grounded outlet installed by a qualified electrician.

Water Supply Requirements

IMPORTANT: If the water pressure to the hot water dispenser system is less than 150kPa (1.5 bar), performance may be affected. Also if the pressure of water inlet is above 500kPa (5 bar), the electronic instant hot water appliance may be damaged and will void the guarantee so an approved pressure reducing valve must be installed by a plumber.

We strongly recommend installing particle filters and isolation valves to both hot and cold feeds. This will help to prevent premature failure of valves and make any future maintenance easier. Flush the plumbing system before installing the mixer tap. This is to void plumbing residues clogging the mesh of the aerated outlet, or possibly damaging the valve's washers. This is especially important where extensive plumbing work has been carried out.

Environment Requirement

Don't install the electronic instant hot water appliance outdoors or in a location that may fall below zero degrees C, otherwise the pipes and the tap may freeze and there may be serious safety risks, possible bodily-injury, accidents and damaged caused.

The installation environment should be ventilated, with protection from the direct sunshine. When installing the electronic instant hot water appliance, provide approximately 10cm to 15cm (4 - 5 1/2") of air space on the sides of the unit for air circulation and approximately 2.5cm (1") from the mounting wall. Ensure that the electronic instant hot water appliance is placed so that you will be able to view and reach the touch control on the front face for adjustments.

The electronic instant hot water appliance must be mounted vertically and level. Before you begin, select a proper location ideally directly under the instant hot water tap or close to it to ensure the connection pipes will connect from the instant hot water tap to the electronic instant hot water appliance.

Instant Hot Water Tap Information

Unlike other household hot water appliances, this electronic instant hot water appliance is Non Pressurised for safety reasons. For this electronic instant hot water appliance, the Instant Hot Tap is placed before the electronic instant hot water appliance, creating an "open vent" system and consequently no pressure is built up inside the appliance. Consequently, there is a slight delay in water flow after the Hot Water Handle has been turned on. This is normal and indicates that the electronic instant hot water appliance is functioning properly.

TANK TEMPERATURE ADJUSTMENT

Selection of water outlet temperature: The machine can set several temperatures according to individual needs to provide options. Each time the "+" button is pressed, the set point temperature of the water outlet is set from low to high, and the machine provides the following temperatures: 45°C -98°C. If you need to lower the temperature of the outlet water, press the "-" key to operate.

TANK PROGRAMS

1. Reheating interval temperature selection after temperature cooling down:

Press the "+" and "-" keys at the same time for 3 seconds, and the word "03" appears. At this time, press "+" to increase the number, and press "-" to decrease the number. 03 represents an interval of 3 degrees Celsius.

And so on: There are four kinds of interval temperature "2, 3, 4, 5" for selection inside. The initial value is "03".

2. Description of the water consumption indicator on the left side of the service life of the filter element:

The tank has a pre programmed 180 day/ 6 month timer, once this time has elapsed the unit will beep repeatedly when a temperature drop is recorded.

This can be reset by pressing and holding the minus (-) button for 5 seconds until you hear a second beep, the visual bar indicator on the left of the screen will also display 6 bars once the reset has been completed.



E1: After starting up, E1 is displayed, indicating that the local voltage does not match the working voltage set by the machine. Power off automatically within 2 seconds.

E3 means: the power is turned on, and E3 is displayed, indicating that the float is reversed, there is no water or the water level is too low. Automatically turn off the power switch within 2 seconds to prevent the heating plate from drying out.

E7: After the machine is turned on, the temperature sensor detects that the low temperature is between -2 °C and 2 °C, indicating that the pipeline is in danger of freezing, the machine displays E7, and the power is turned off within 2 seconds.

E8: After the heating is completed, the temperature sensor detects an excessively high temperature, exceeding 100°C, and displays E8. (collected by temperature sensor)

E9: The temperature does not rise within 120 seconds after the power is turned on, and E9 is displayed, indicating that the temperature sensor NTC is faulty, or the heating plate is invalid.

To turn off the electronic instant hot water appliance at any time press the  button.

MAINTENANCE AND CARE

If the electronic instant hot water appliance is not being used for long periods of time ie: over 7 days, to save power we recommend you switch off using the plug switch. Isolate the tank via (C7) Flush the system out before using again. If you suffer from a reduction in flow rate follow the descale guide below. We recommend you descale your tank every 12 months. Soft scale can still build up in the tank even though you have a filter installed. Certain areas suffer from harder water than others, if you are in a very hard water area, we suggest doing this every 6-9 months. If you suffer from a reduction in flow rate follow the descale guide below.

DESCALE GUIDE

We recommend you descale your tank every 12 months. Soft scale can still build up in the tank even though you have a filter installed. Certain areas suffer from harder water than others, if you are in a very hard water area, we suggest doing this every 6-9 months. If you notice a drop in flow rate, long run off's after use or dripping. It is likely you need to descale your tank.

1. Turn off and allow the tank to cool.
2. Release C19 clip on silicone pipe using pliers and pull silicone pipe away from barbed outlet. Release push-fit tank feed connector by depressing inner sleeve and pulling connector away from the outlet.
3. Using descaling fluid, pour the fluid into the tank via Red & Blue inlets. Follow the decaling product instructions for time and double the mixture strength.
4. Drain and repeat the process again.
5. Reconnect tank fittings.
6. Run the kettle valve so that around 4 liters of water has passed and then switch the tank on and allow to heat fully. (Note: water will not exit the spout until the system is full of water). Run an additional 2 liters off once the tank is at temperature.

TROUBLE SHOOTING

PROBLEM	POSSIBLE CAUSE	WHAT TO DO
Water and Steam is spitting from the instant hot water tap spout.	Unit is boiling.	Unplug the tank and contact Sterling.
Water is not hot.	The electronic display has not been powered up.	Turn on the power and touch the on/off button and then set the required temperature and confirm the heat up.
Water is too hot.	Water temperature setting on display panel is set too high.	Re-set the temperature to the required temperature and confirm the heating up.

TROUBLE SHOOTING

PROBLEM	POSSIBLE CAUSE	WHAT TO DO
Water is dripping from the instant hot water tap spout.	The expansion chamber isn't draining the system correctly due to very small draw off of water.	Draw off 0.5L of water to clear and prime the system. Avoid less than 150ml draw offs of water.
	Lime-scale build up.	Descalate the tank as per page 11.
Slow flow from the spout.	Water Filter may be clogged from impurities in the inlet mains water.	The water filter must be changed every 6 months or this will void the guarantee.
Water does not flow straight away.	The electronic instant hot water appliance is design for non-pressurised operation and there will be slight delay till the near boiling water appears.	After a large volume of water has been drawn off there slightly longer delay in the water appearing from the hot water tap spout.
No water flowing.	Water Valves have been turned off.	Turn on all the water valves.
	Inlet pipes have been twisted or blocked.	Ensure the pipes are not twisted or kinked to restrict flow.
	Aerator blocked.	Remove and clean the aerator.
	Lime-scale build up.	Descalate the tank as per page 11.

IF YOU ARE IN ANY DOUBT THEN POWER OFF THE ELECTRONIC INSTANT HOT WATER APPLIANCE AND CALL STERLING

FILTER CARTRIDGE INSTALLATION

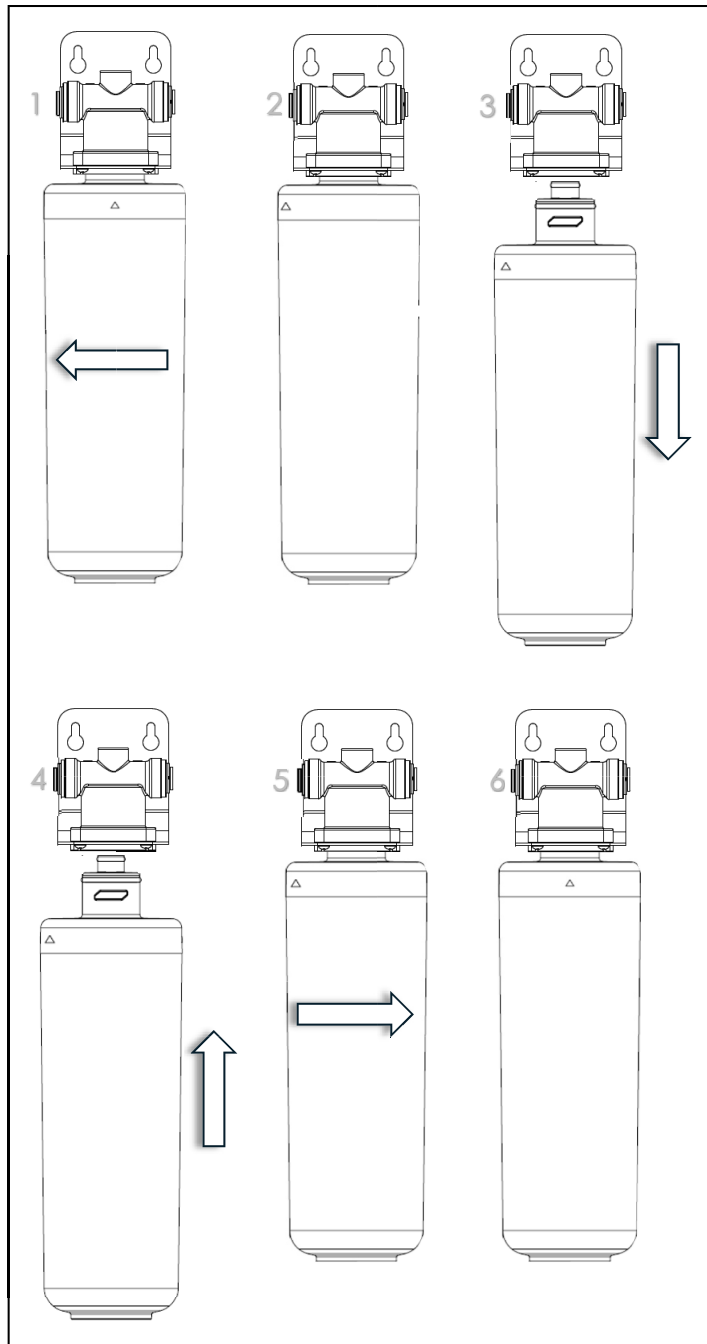

FILTER REMINDER RESET

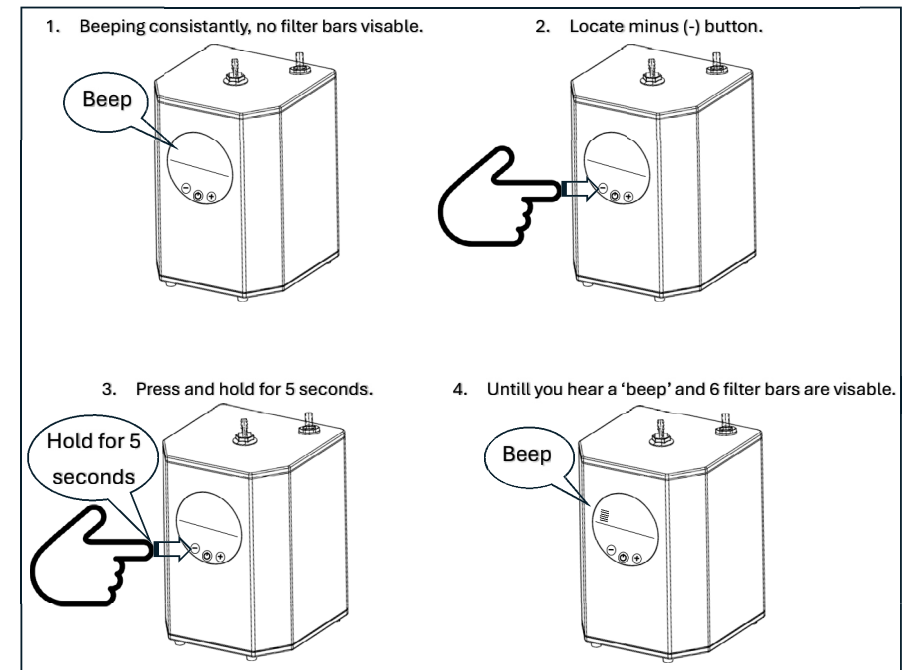

REGISTER YOUR WARRANTY

The Clearwater Kettle water filter must be replaced every 6 months regardless of the filter icon position. Failure to do so will invalidate your product warranty. Only use genuine Clearwater kettle filters.

Register your warranty:

Fill in your free post form or register your tap/tank by scanning the QR

